



2007-2008 MCPA Partnership Opportunities

As leaders and partners in the concrete paving industry, you now have another opportunity to show your support by sponsoring one or more MCPA programs during the upcoming year. Recognizing that budget cycles vary, MCPA hopes this packet will provide you with enough time to incorporate these marketing opportunities in your budget.

For your convenience, a variety of levels of sponsorships are available. All opportunities will provide visibility among current and prospective customers. In addition you will receive a mention in one of MCPA's top resources, *Concrete Solutions*®.

Opportunities are available on a first-come, first-served basis. To confirm your sponsorship(s), please fill out the appropriate commitment form and return it to the MCPA office via fax at (517) 347-7740.

We look forward to sharing the success of the 2007-2008 program year with you!

Inside Information

Annual Workshop Sponsors.....	Page 2
Annual Workshop Exhibitors.....	Page 5
Annual Concrete Pavement Award Sponsors.....	Page 8
Annual Golf Outing.....	Page 11

2008 MCPA Annual Workshop

Key Data: Wednesday and Thursday, February 20-21, 2008
Troy Marriott — Troy Michigan

Historically, this conference has generated interest among over 200 engineers from the Michigan Department of Transportation, consultants, city, and county road commissions.

Partnership

Benefits: Conference partners will each receive a set of MCPA member mailing labels for use with their own pre-event mailer announcing not only your support of the Conference, but also the services and special opportunities you wish to market.

Partners also receive professional signage at the workshop, listing in MCPA's Bi-monthly newsletter, *Concrete Solutions*®, listing on MCPA's web site with direct link to yours (if provided), and written recognition at the Conference.



2008 MCPA Annual Workshop **Sponsorship Opportunities**

February 20-21, 2008

Troy Marriott, Troy Michigan

Workshop Sponsorship

\$3,000.00

For the maximum exposure, this sponsorship will give sponsors a strong presence throughout the event. This sponsorship includes the opportunity to greet attendees at the registration table, place collateral materials in the registration packets, display collateral items in registration area, a listing in *Concrete Solutions*®, recognition in onsite packet and on MCPA's web site, signage at the conference, and up to 2 complimentary workshop registrations.

Luncheon Sponsorship (3 available)

\$2,400 or \$800.00 each

This sponsorship offers a great deal of exposure at the conference. This sponsorship includes a display table in the luncheon room during lunch, the opportunity to place collateral and/or gifts at each seat in the lunch room, a listing in *Concrete Solutions*®, recognition in onsite packet and on MCPA's web site, signage at the conference, and 1 complimentary registration.

Breakout Session Sponsorship (3 available)

\$500.00

The breakout sponsorship offers the opportunity to place collateral materials in the breakout room during the sponsored session, an introduction of the breakout session speakers, a listing in *Concrete Solutions*®, recognition in onsite packet and on MCPA's web site, and signage outside the sponsored breakout room.

Speakers Reception Sponsorship (3 available)

\$1,500.00 or \$500.00

This sponsorship offers wonderful exposure at the conference. This sponsorship includes a display table in the Reception area during the reception on Wednesday evening, a listing in *Concrete Solutions*®, recognition in onsite packet and on MCPA's web site, and signage at the conference.

Supporter Sponsorship

\$300.00

This sponsorship offers wonderful exposure at the conference. This sponsorship includes a listing in *Concrete Solutions*®, recognition in onsite packet and on MCPA's web site, and signage at the conference.

Please complete the sponsorship form and return it with payment to:

MCPA

2111 University Park Dr., Suite 550

Okemos, MI 48864-6913

Phone (517) 347-7720 ext. 10

Fax (517) 347-7740

www.durableroads.com

2008 MCPA Annual Workshop

Sponsorship Commitment Form

February 20-21, 2008
Troy Marriott, Troy Michigan

_____ is pleased to be a 2008 MCPA Annual Workshop
(Company Name)
sponsor of the item(s) noted below. I understand that MCPA staff will contact the person listed below two weeks before the conference to confirm the names of the complimentary registrant(s), if applicable.

- | | | |
|-----------------------|---------------------------------------------------------------------|-------------------|
| <input type="radio"/> | Workshop Sponsorship | \$3,000.00 |
| <input type="radio"/> | Luncheon Sponsorship | \$2,400.00 |
| <input type="radio"/> | <input type="radio"/> Partial Luncheon Sponsorship | \$ 800.00 |
| <input type="radio"/> | Breakout Session Sponsorship | \$ 500.00 |
| <input type="radio"/> | Speakers Reception Sponsorship | \$1,500.00 |
| <input type="radio"/> | <input type="radio"/> Partial Speakers Reception Sponsorship | \$ 500.00 |
| <input type="radio"/> | Supporter Sponsorship | \$ 300.00 |

Name: _____ Title: _____

Organization: _____

Address: _____

City/State/Zip: _____

Phone: _____ Fax: _____ Email: _____

Payment Methods: Check Enclosed Amex Visa Master Card Discover

Credit Card Number: _____ **Expiration:** _____

Cardholder Name: _____ **Signature:** _____

Billing Address: _____

Thank you for your sponsorship, please return this form with your payment to MCPA. You may fax or email the form back to MCPA at (517) 347-7740 or kimmoore@miconcpave.com and follow with payment.

**IN ORDER TO ACCOMADATE ALL EXPOSURE OPPORTUNITIES
FORMS MUST BE INTO THE OFFICE BY JANUARY 31, 2008.**

MCPA

2111 University Park Drive, Suite 550 * Okemos, MI 48864-6913
Phone (517) 347-7720 ext. 10 * Fax (517) 347-7740 * www.durableroads.com

2008 MCPA Exhibitors Annual Workshop

Key Data: Wednesday and Thursday, February 20-21, 2008
Troy Marriott — Troy Michigan

Historically, this conference has generated interest among over 200 engineers from the Michigan Department of Transportation, consultants, city, and county road commissions.

Partnership

Benefits: Conference partners will each receive a set of MCPA member mailing labels for use with their own pre-event mailer announcing not only your support of the Conference, but also the services and special opportunities you wish to market.

Partners also receive professional signage at the workshop, listing in MCPA's Bi-monthly newsletter, *Concrete Solutions*®, listing on MCPA's web site with direct link to yours (if provided), and written recognition at the Conference.

37th ANNUAL WORKSHOP
MICHIGAN CONCRETE PAVING ASSOCIATION
DISPLAY TABLE RESERVATION FORM

The registration fee covers lunch, refreshment breaks, and workshop sessions for **one attendee**. Please attach your check made payable to the "Michigan Concrete Paving Association" or credit card information and mail along with this form to:

Michigan Concrete Paving Association
 2111 University Park Dr., Suite 550
 Okemos, Michigan 48864-6913
 Phone: (517) 347-7720
 Fax: (517) 347-7740

EXHIBITOR MEMBER RATE	EXHIBITOR NON-MEMBER RATE
\$300.00	\$500.00
Additional People \$150.00	Additional People \$250.00

Our Choice for Booth location (see map) First _____ Second _____ Third _____

Our check is enclosed in the amount of \$ _____ .is enclosed.

Please bill the following credit card:

NAME ON CARD: _____

COMPANY: _____

BILLING ADDRESS: _____

CITY: _____ STATE: _____ ZIP CODE: _____

PHONE: (____) _____ FAX: (____) _____

Credit Card:

MasterCard	Visa	American Express	Discover
Credit Card Number			

Signature _____ Date: _____

(Space can be reserved with a copy of a purchase order or a letter stating that payment will be made by January 31, 2008)

PERSON ATTENDING

NAME: _____ NAME: _____

TITLE: _____ TITLE: _____

E-mail: _____ E-mail: _____

Name for Badge: _____ Name for Badge: _____

(List Additional Names on Separate Sheet)

IN ORDER TO RESERVE A TABLE FORMS MUST BE INTO THE OFFICE BY JANUARY 31, 2008.

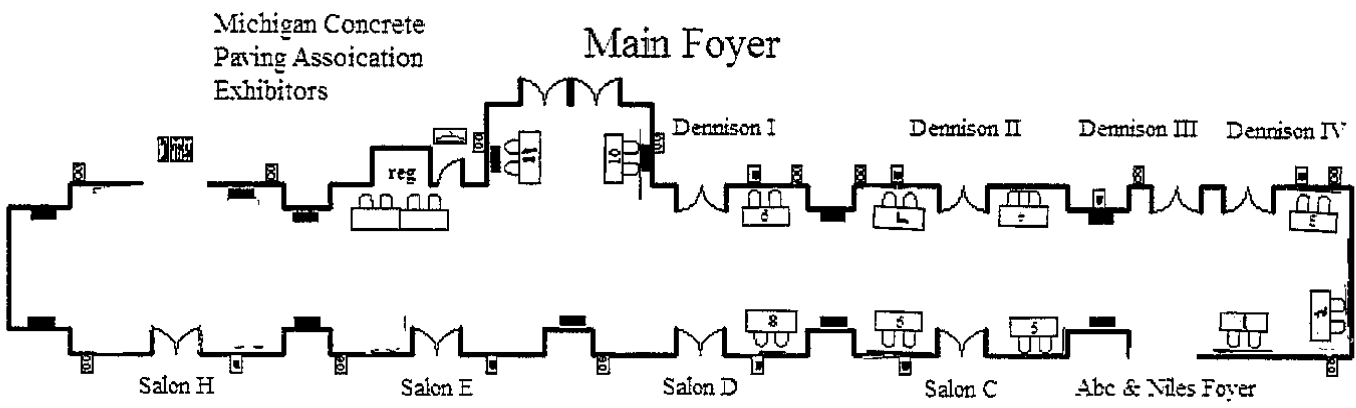

Registration is near men's/women's bathroom. General Session is held in Salons A-D
 Locations are on a first come first served basis.

MCPA Concrete Pavement Awards

Key Data: Thursday, February 21, 2008
Troy Marriott — Troy Michigan

Schedule:	Reception	5:00 p.m. – 6:30 p.m.
	Dinner	6:30 p.m. – 7:30 p.m.
	Awards	7:30 p.m. – 9:00 p.m.

We are pleased to provide the leading platform for celebrating professional achievements for contractors, owner and engineers who use concrete paving in Michigan.

Confirmed recognition, both as an individual and as a business, is a significant component of our industry's appreciation process. How else do we evaluate our best practices? What better way to celebrate our achievements and learn from our peers?

Partnership Benefits: Partners receive a number of outstanding benefits by supporting this program.

- Reach more than 300 engineers and specifiers from across the state
- Receive a prominent reserved table near the presentation stage and recognition during the awards program
- Network with an impressive group of peers in the concrete paving industry
- Demonstrate your support for concrete paving in our state
- Support a program that rewards excellence and innovation
- Receive recognition on signage at the event

Four levels of support offering varying benefits are available, so select the one that is best suited for your company.

MCPA Awards Partnership Opportunities

\$2,000 Diamond Partner

The \$2,000 partners will enjoy a “diamond” experience at the Workshop:

- Prominently mentioned in all press releases and interviews regarding the event
- Complimentary 1/2-page black & white advertisement in the spring issue of *Concrete Solutions*® near the announcement of winners
- Special seating for ten at the front of the room during the February awards dinner
- Free hyperlink on the MCPA website
- Recognized in promotional materials
- Full-page ad in the program book
- Partnership verbally announced during the awards program
- Recognition on signage at the Workshop

\$1500 Gold Sponsor

\$1500 partners will enjoy a “gold” experience at the Workshop:

- Six complimentary tickets to the dinner event with special seating at the front
- Free hyperlink on the MCPA website
- Listed in promotional materials
- Half page ad in the program book
- Partnership verbally announced during the awards program
- Recognition in *Concrete Solutions*® as being a partner
- Recognition on signage at the Workshop

\$500 Silver Sponsor

\$500 partners will enjoy a “silver” experience at the Workshop:

- Four complimentary tickets to the dinner event with special seating
- Recognition in *Concrete Solutions*® as being a partner
- Listed in promotional materials
- Recognition in the program book
- Partnership verbally announced during the awards program
- Recognition on signage at the Workshop

\$250 Bronze Sponsor

\$250 partners will enjoy a “bronze” experience at the Workshop:

- Two complimentary tickets to the dinner event with special seating
- Listed in promotional materials
- Recognition in the program book
- Partnership verbally announced during the awards program
- Recognition on signage at the Workshop

**Michigan Concrete Paving Association
Annual Concrete Pavement Awards Dinner
Commitment Form**

Each category of support includes a specially tailored marketing package. See Partnership Opportunities Sheet for details. If you have questions about the Awards Program or Partnership Opportunities, please contact Kim Moore.

- YES, I am interested in showing our support in the concrete paving industry by supporting the Awards program. Please sign me up for the partnership level marked below.
 - \$2,000 Diamond Partner \$1,500 Gold Partner
 - \$ 500 Silver Partner \$ 250 Bronze Partner

- YES, I am interested in discussing this opportunity and/or Award investment options including in-kind contributions, purchasing advertising, etc. Please call me.

- No, I am not presently interested in making an investment in the Awards Program but would like to discuss other ways to increase my organization's visibility in the association. Please call me.

Name _____
Title _____
Organization _____
Address _____
City/State/Zip _____
Phone _____ Fax _____
Email _____

Payment Information

- Check enclosed (made payable to MCPA)
- Please send me an invoice (members only)
- MasterCard/Visa/AMEX/Discover

Account Number _____ Expiration _____
Billing Address _____
City/State/Zip _____

Signature _____

To accommodate your budget schedules, MCPA can arrange for sponsorship billing in either this calendar year or the next. NOTE: All funds commitments must be received by December 15, 2007 to be included in promotions.

Please return by January 31, 2008 to:

Michigan Concrete Paving Association
2111 University Park Dr., Suite 550, Okemos, MI 48864-6913
Phone: 517-347-7720 Fax: 517-347-7740

MCPA Annual Golf Outing

Key Data: Wednesday, June 25, 2008
Timber Ridge Golf Course, Bath, Michigan

Historically, this outing generates interest among 120 - 144 golfers. Approximately half of the golfers are local agency decision makers and contractors.

Partnership

Benefits: Conference partners will each receive a set of MCPA member mailing labels for use with their own pre-event mailer announcing not only your support of the Conference, but also the services and special opportunities you wish to market.

Partners also receive professional signage at the outing, listing in MCPA's bi-monthly newsletter, *Concrete Solutions*®, listing on MCPA's web site with direct link to yours, and both verbal and written recognition at the outing.

Partners who secure opportunities with payment **before March 31, 2008** will also be listed on the main Outing promotional piece sent to MCPA members, prospects, and past golfers.

MCPA Annual Golf Outing Partnership Opportunities

Wednesday, June 25, 2008

Sponsorship opportunities are available for this year's golf scramble. If you are interested in sponsoring one of these items, please fax this completed form back to the MCPA office at (517) 347-7740. Items are available on a first-come, first-served basis.

I would like to sponsor the following item(s) at the 2008 MCPA Annual Golf Outing. Please note that most items are available for co-sponsorship. You may provide both co-sponsor names or pair with someone else who contacts MCPA directly.

<input type="checkbox"/>	Golf Carts Sponsor may furnish cart signs and provide all golfers with special memento. Sponsor receives professional signage in cart loading area, recognition in <i>Concrete Solutions™</i> , and in on-site flyer.	<input type="checkbox"/> \$1000.00 <input type="checkbox"/> \$500 co-sponsor
<input type="checkbox"/>	Outing Dinner Sponsor may decorate club house, provide all golfers with special memento, and receives professional signage during the dinner, recognition in <i>Concrete Solutions™</i> , and in onsite flyer.	<input type="checkbox"/> \$1200.00 <input type="checkbox"/> \$600 co-sponsor
<input type="checkbox"/>	Beverage Carts (2) Course allows sponsor to ride cart to give gifts to golfers; sponsor receives professional signage on the beverage cart(s), recognition in <i>Concrete Solutions™</i> , and in onsite flyer.	<input type="checkbox"/> \$800.00 <input type="checkbox"/> \$400 co-sponsor
<input type="checkbox"/>	Lunch at the Turn Sponsor may provide all golfers with a special memento during lunch, receives professional signage during the lunch, recognition in <i>Concrete Solutions™</i> , and in onsite flyer.	<input type="checkbox"/> \$600.00 <input type="checkbox"/> \$300 co-sponsor
<input type="checkbox"/>	Golfer Giveaway Sponsor may provide all golfers with a special memento or let MCPA pick out (Sponsors Logo can be added to item), receives professional signage during registration, recognition in <i>Concrete Solutions™</i> , and in onsite flyer.	<input type="checkbox"/> \$500.00 <input type="checkbox"/> \$250 co-sponsor
<input type="checkbox"/>	Continental Breakfast Sponsor may provide golfers with special memento, and receives professional signage during the continental breakfast, recognition in <i>Concrete Solutions™</i> , and in onsite flyer.	<input type="checkbox"/> \$200 sponsor
<input type="checkbox"/>	Hole Sponsorship Unlimited opportunities are available. Sponsor receives a sign at hole.	<input type="checkbox"/> \$250.00

Name: _____ Title: _____

Organization: _____

Address: _____ City/State/Zip: _____

Telephone: _____ Email: _____ Fax: _____

My Check is enclosed for: \$ _____

Please charge my credit card. Here is the information:

Visa Master Card American Express Personal Card Business Card

Card Number _____ Expiration Date: _____

Signature _____

Billing Address _____

Please return this form and payment to MCPA. MCPA*2111 University Park Dr, Suite 550
 *Okemos, MI 48864*Phone: (517) 347-7720 ext. 10 *Fax: (517) 347-7740

